

Models GEO-IR20 & GEO-IR20WS

Research grade pyrgeometers

GEO-IR20 is a research grade pyrgeometer suitable for high-accuracy longwave irradiance measurement in meteorological applications. Thanks to technological innovation, GEO-IR20 is offered at a significantly lower price level than competing models of the same performance level. GEO-IR20 is capable of measuring during both day and night. In absence of solar radiation, model GEO-IR20WS offers even better accuracy because of its wider spectral range.



Figure 1 GEO-IR20 research grade pyrgeometer

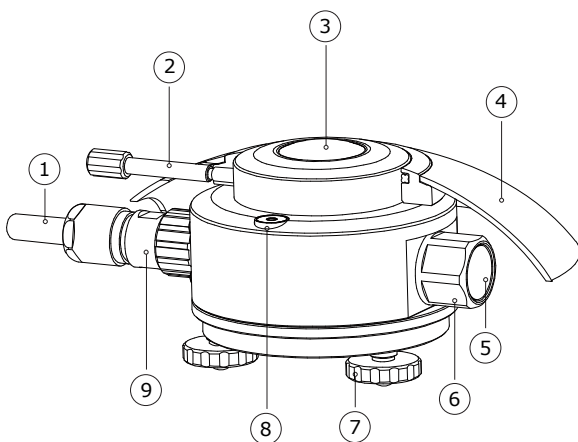

Figure 2 overview of GEO-IR20 pyrgeometer:
(1) cable, (2) fixation of sun screen, (3) dome with solar blind filter, (4) sun screen, (5) humidity indicator, (6) desiccant holder, (7) levelling feet, (8) bubble level, (9) connector

Introduction

GEO-IR20 measures the longwave or far-infra-red radiation received by a plane surface, in W/m^2 , from a 180° field of view angle.

In meteorological terms pyrgeometers are used to measure "downward and upward longwave irradiance" (WMO definition). Longwave radiation is the part of radiation that is not emitted by the sun. The spectral range of longwave radiation is not standardised. A practical cut-on is in the range of 4 to 5×10^{-6} m. GEO-IR20 has a dome with a solar blind filter with a cut-on at 4.5×10^{-6} m, making it suitable for day- and night observations.

Model GEO-IR20WS has a wide spectral range with a cut-on at 1.0×10^{-6} m. It offers a superior accuracy during night-time, when solar radiation is absent.



METEODATA 3000
Datalogger with integrated comms
(3G/GPRS, Line, Radio or Satellite)

GEO-IR20 & GEO-IR20WS design & benefits

- breakthrough pricing for a pyrgeometer of this performance level as a result of Hukseflux' technological innovation.
- correction of temperature dependence by use of the measurement function. This is far more accurate than temperature compensation in the instrument, especially at very low and high temperatures. Every pyrgeometer is supplied with temperature coefficients to enter into the equation.
- high sensitivity. With sufficient input signal a typical datalogger no longer significantly contributes to the uncertainty of the measurement.
- low thermal-resistance of the sensor. Competing designs need a significant correction for the difference in temperature between pyrgeometer body and sensor surface. For GEO-IR20 this is not needed.
- fast response time (3 s). A low response time is a benefit for measurements on moving platforms such as aircraft and buoys.
- on-board heater. Heating prevents condensation of water on the pyrgeometer dome which, when occurring, leads to very large measurement errors.
- instrument cut-on wavelength (5 %) and the two 50 % transmission points are displayed on the product certificate for individual sensors.

GEO-IR20 & GEO-IR20WS specifications

Measurand	longwave radiation
Optional measurand	sky temperature
Optional measurand	surface temperature
Spectral range GEO-IR20	4.5* to 40×10^{-6} m
Spectral range GEO-IR20WS	1.0 to 50×10^{-6} m
GEO-IR20WS restrictions for use	only in the absence of solar radiation
Field of view angle	180°
Response time (95 %)	3 s
Sensitivity (nominal)	17×10^{-6} V/(W/m ²)
Rated operating temperature range	-40 to +80 °C
Temperature dependence	± 0.4 % (-30 to +50 °C)
Zero offset	± 2 W/m ²
Steady state 0, offset caused by heating	0 W/m ²
Non- linearity	± 0.5 %
Calibration traceability	to WISG
Optional traceability	to blackbody (ITS-90)
Temperature sensor	10 kΩ thermistor
Heater	12 VDC, 1.5 W
Standard cable length	5 m

*nominal, see product certificate for individual value
typical 4.5 to 45×10^{-6} m

Options

- longer cable, in multiples of 5 metres
- blackbody calibration (ITS-90)

Suggested use

- climatological networks
- extreme climates (polar / tropical)
- moving platforms (aircraft, buoys)
- uncertainty assessment (GEO-IR20 + GEO-IR20WS)
- calibration reference (GEO-IR20WS)

See also

- **GEO-IR02** for lower accuracy measurements
- pyrgeometers are often used in combination with pyranometers for solar radiation (shortwave) measurement. View our complete [product range of solar sensors](#)
- [The making of GEO-IR20](#) documented